

### Worm Gear Reducers

5mm Input Shaft Double Sided • 6mm Output Bore  
 15mm Centre Distance •  $T_{2max}$  2Nm – 3.5Nm • **6.66:1 - 80:1**

**Worm Gear Rotation Direction.**

**RH-Right Hand**

When input rotation is clockwise , output gear is pulled towards input.

When input is counter-clockwise , output gear is pushed away from input.

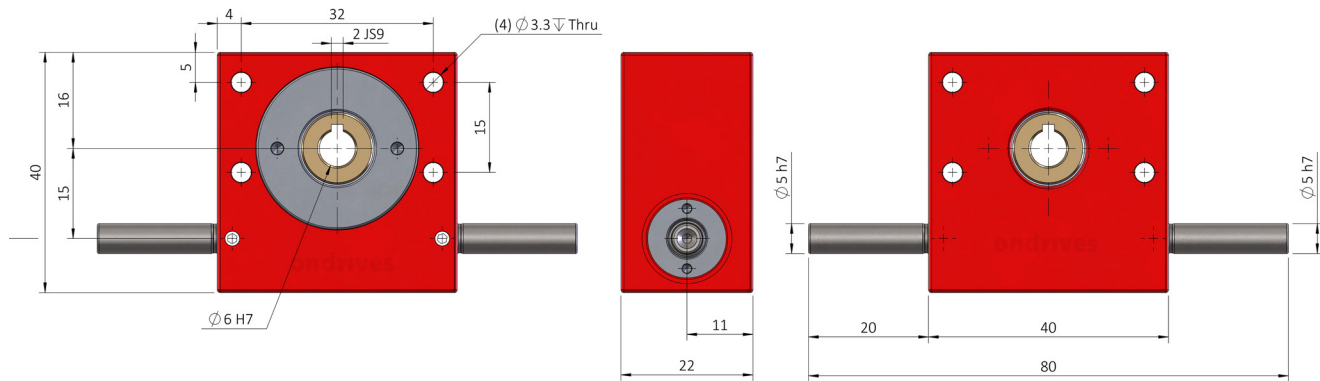
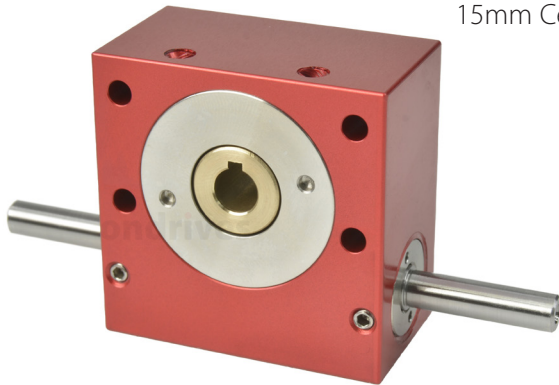

	Part Numbers					
Output Backlash j	Output Backlash j A	Output Backlash j AR	Gear Ratio i	Efficiency $\eta z$	Lead Direction	Reflected Inertia at Input $kg \cdot m^2$
$\leq 0.50^\circ$	$\leq 0.13^\circ$	$\leq 0.066^\circ$		<b>n1nom</b>		
P15-6	P15-6A	P15-6AR	6.666:1	86%	Right Hand	$1.79 \times 10^{-7}$
P15-8	P15-8A	P15-8AR	8:1	85%	Right Hand	$1.73 \times 10^{-7}$
P15-10	P15-10A	P15-10AR	10:1	84%	Right Hand	$1.68 \times 10^{-7}$
P15-13	P15-13A	P15-13AR	13.333:1	78%	Right Hand	$1.65 \times 10^{-7}$
P15-20	P15-20A	P15-20AR	20:1	71%	Right Hand	$1.62 \times 10^{-7}$
P15-40	P15-40A	P15-40AR	40:1	60%	Right Hand	$1.61 \times 10^{-7}$
P15-80	P15-80A	P15-80AR	80:1	32%	Right Hand	$1.60 \times 10^{-7}$

**Weight:** 0.15 kg.

**Nom. Input Speed [S1 T<sub>2</sub>n] n1nom:** 1,000 min<sup>-1</sup> (r/min)

**Max. Input Speed n1max:** 3,000 min<sup>-1</sup> (r/min)

**Lubrication:** Grease Shell Gadus S5 V4P 2.5

**Lubrication Temperature:** Max. Operating  $\approx 60^\circ C$

**Max. Input Radial Load F<sub>r1</sub>:** 10N.

**Max. Output Radial Load F<sub>r2</sub>:** 80N.

**Max. Output Axial Load F<sub>a2</sub>:** 30N.

Testing in your application is necessary.

You will need to assess duty cycles and confirm suitability with your own calculations.

Figures listed are for guidance only.

Cooling may be needed dependent on application.

### Worm Gear Reducers

5mm Input Shaft Double Sided • 6mm Output Bore  
15mm Centre Distance •  $T_{2max}$  2Nm – 3.5Nm • **6.66:1 - 80:1**

P15 Series Wormwheel Gearboxes

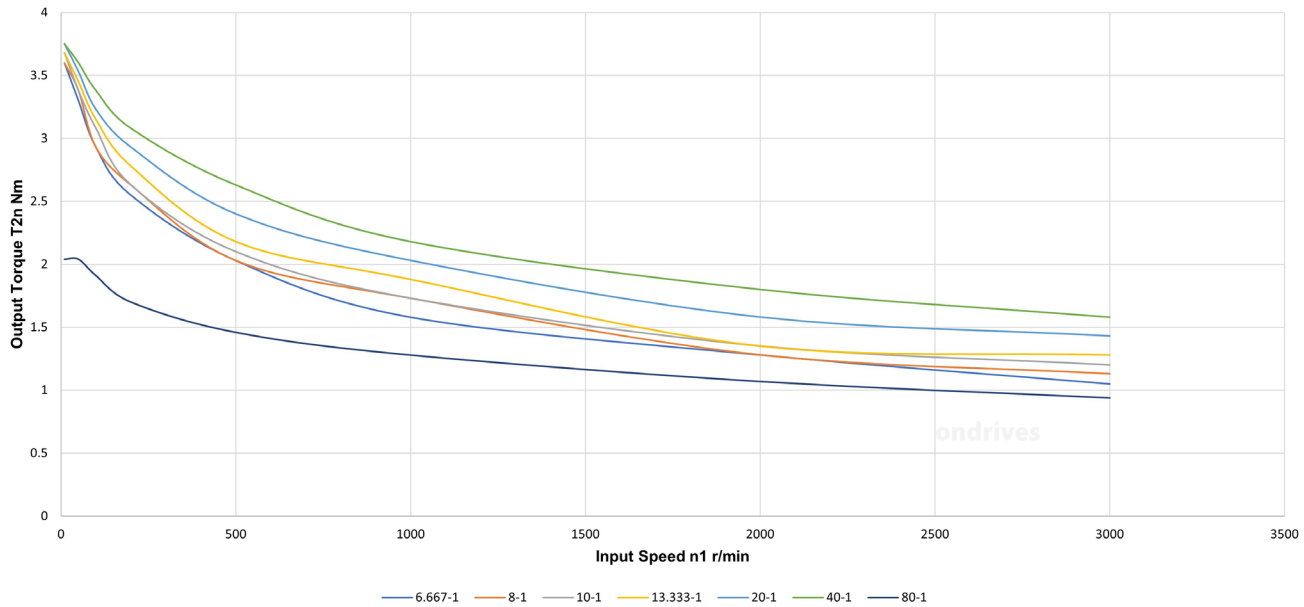

Worm Gear Reducers